

# THD Series

from 19 to 21 m

The GSR "THD" is known for the exceptional strength and rigidity of the aerial platform and its simple and intuitive operation. The high product quality and excellent performance parameters of the telescopic boom with unrestricted outreach at full basket capacity are secured by applying traditional and reliable technical solutions, as well as special steels and boom profiles.

Protected internal hosing together with self-cleaning brushes fitted to the telescopic sections prevent dirt and debris entering the boom. The hydraulic joysticks are housed for protection, robust and durable and allow the operator to perform all movements, even at full working height with smoothness and accuracy.

Outrigger controls allow for individual leg operation ensuring effective ground contact and levelling on uneven surfaces.

The machines can be fitted on the most popular commercial vehicles starting from 7,5t. Different vehicle installations are possible by varying outrigger configurations and tailoring working envelopes to optimise each mounting.



GB





## Standard features include

- Fully proportional hydraulic controls with multifunction joysticks
- Simultaneous and independent movements
- Telescopic cylinder mounted below the booms and internal housed hoses for maximum protection
- Easy access to the basket
- Tubular steel or fibreglass basket
- Automatic basket leveling
- Hydraulic basket rotation
- Control panels protected against accidental collision
- Cleaning brushes on all telescopic boom sections
- Turret rotation on self braking slewing system
- Colour scheme white RAL 9010 for the aerial platform, black RAL 9011 for the cylinders
- Rectangular boom
- Antislip aluminium decking
- Vehicle engine start / stop from the basket

## Safety

- Outrigger / Boom interlocks
- Emergency stop at the basket and the ground control points
- Failsafe lock valves to all hydraulic cylinders
- Spirit level indicator
- Emergency controls located on the base
- Control lights in the cab indicating outriggers grounded and in stowed position
- Manual emergency pump
- Conformity declaration (CE)

## Extra accessories

- Electric emergency pump
- Hour meter connected to the power take-off of the vehicle
- 230/110V wiring to the basket
- Mains powered electric motor for engine-off use (switched from the ground)
- Rotating beacon
- Safety harness and lanyard
- Spotlight in the basket
- Special painting
- N. 4 wooden outrigger pads
- N. 4 steel outrigger pads
- Tool box under the decking
- Walk-In fibreglass basket
- Cab protection
- 1kV electric insulation

Wide series of vehicle fittings and accessories available. For detailed information contact sales office.

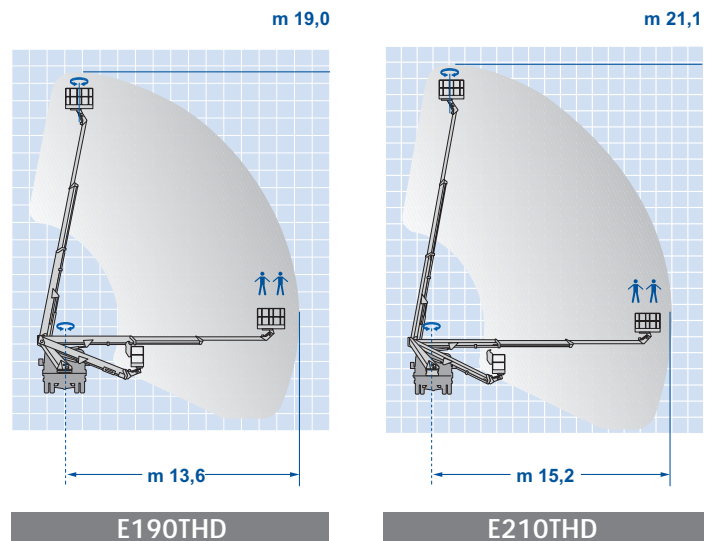

MODEL	Working Height (m)	Max. Outreach (m)	Basket Capacity (kg)	Turret Rotation (°)	Basket Rotation (°)	GWV min. (to)
E190THD	19,0	13,6	250	450	55 + 50	7,5
E210THD	21,1	15,2	250	450	55 + 50	7,5